

TORQUE MULTIPLIERS

EGA Master produces a wide range of **EGATORIK** controlled tightening, torque multipliers being part of them.

EGA Master Torque multipliers are the ideal complement for Digital Torque Wrenches, which increase the input torque in proportion of 4 or 20, allowing high output torques for specials requests.



Example:

To obtain an output torque of 1800Nm, user should apply an input torque of:

$$\text{Input torque} = \text{output torque} \times \text{net ratio}$$

$$1800 \times 1/4.5 = 400\text{Nm}$$

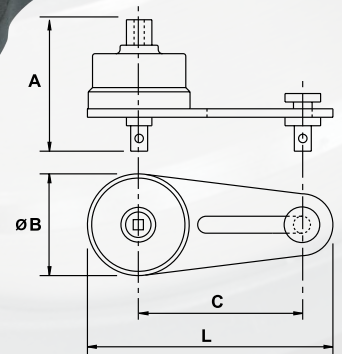
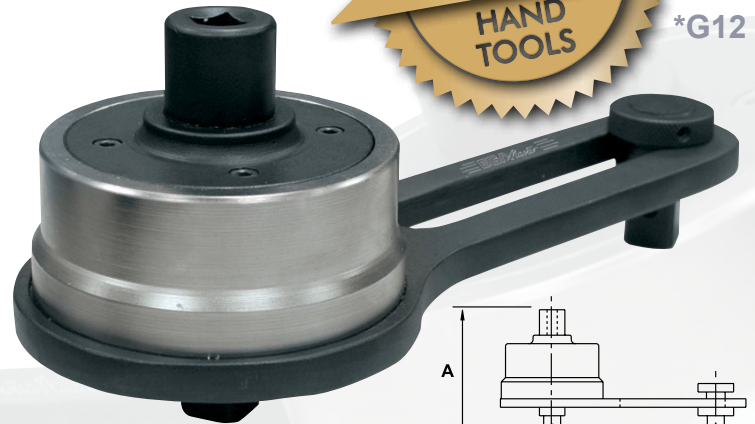

COD	OUT (MAX)		RATIO	IN (MAX)		IN		OUT		Kg.	Models		
	N.m	Lb.ft		N.m	Lb.ft	IN	OUT	L	A			ØB	C
63850			4,5:1	378	279	1/2"	3/4"	310	120	120	250	4,5	62954 / 62957 / 62958 / 62961 / 62962 / 62963 / 62968
63851	1700	1250		3/4"									
63852			22,5:1	75	55	1/2"	1"	200	145	140	260	7,0	62954 / 62957 / 62958 / 62961 / 62962 / 62963 / 62968
63853	2700	2000	4,5:1	600	442	3/4"							
63854			22,5:1	120	88	1/2"	1 1/2"	365	200	140	260	12	62954 / 62957 / 62958 / 62961 / 62962 / 62963 / 62968
63855	3400	2500	4,5:1	750	553	3/4"							
63856			22,5:1	150	110	1/2"	1 1/2"	205	170	185	360	14	62954 / 62957 / 62958 / 62961 / 62962 / 62963 / 62968
63857	6000	4500	4,5:1	1325	977	3/4"							
63858			22,5:1	264	194	1/2"	1 1/2"	445	250	185	360	23	62954 / 62957 / 62958 / 62961 / 62962 / 62963 / 62968
63859	9500	7000		420	309	3/4"	2 1/2"					505	290

TECHNICAL SPECIFICATIONS

Cr-V

COD	TORQUE MULTIPLICATION RATIO	NET RATIO	PERFORMANCE (%)	ACCURACY (%)	NON-RETURN SYSTEM
63850	5:1	4,5:1	90	±4	-
63851		4,5:1			-
63852	25:1	22,5:1			•
63853	5:1	4,5:1			-
63854	25:1	22,5:1			•
63855	5:1	4,5:1			-
63856	25:1	22,5:1			•
63857	5:1	4,5:1			-
63858	25:1	22,5:1	•		
63859			•		

NON-RETURN SYSTEM

Torque multipliers with a 22.5:1 relation gearbox, include a non-return system to avoid the reaction induced in the grip. This system locks up the nut, not allowing the torque multiplier to rewind, due to the high ratio level supported. These guarantees the user a safe, easy and comfortable use. All models have a special case in order to be well protected and easy to transport.

*12 MONTHS OF WARRANTY